

RF02-N

Rotary type / Limit rotation specification



- CE compliance
- Rotation range : 310°

Ordering method

RF02	N			L			S2	
Model	Return-to-origin method N: Stroke end (Limit rotation)	Bearing N: Standard H: High rigidity	Torque N: Standard torque H: High torque	Cable entry location L: From the left	Rotation direction N: CCW Z: CW	Cable length <small>Note 1</small> 1K: 1m 3K: 3m 5K: 5m 10K: 10m	Robot positioner S2: TS-S2 <small>Note 2</small>	I/O NP: NPN PN: PNP CC: CC-Link DN: DeviceNet™ EP: EtherNet/IP™ PT: PROFINET GW: No I/O board <small>Note 3</small>
							SH	Battery B: With battery (Absolute) N: None (Incremental)
							SD	1
							Robot driver SD: TS-SD	I/O cable t: 1m

Note 1. The robot cable is flexible and resists bending.
 Note 2. See P.634 for DIN rail mounting bracket.
 Note 3. Select this selection when using the gateway function. For details, see P.96.

Basic specifications

Motor	□ <input type="checkbox"/> Step motor	
Resolution (Pulse/rotation)	4096	
Repeatability <small>Note 1</small> (°)	±0.05	
Drive method	Special worm gear + belt	
Torque type	Standard	High torque
Maximum speed <small>Note 2</small> (°/sec)	40	280
Rotating torque (N·m)	2	3
Max. pushing torque (N·m)	1	1.5
Backlash (°)	±0.5	
Max. moment of inertia <small>Note 3</small> (kg·m ²)	0.018	0.03
Cable length (m)	Standard: 1 / Option: 3, 5, 10	
Rotation range (°)	310	

Note 1. Positioning repeatability in one direction.
 Note 2. The maximum speed may vary depending on the moment of inertia. Check the maximum speed while referring to the "Moment of inertia vs. Acceleration/deceleration" graph and the "Effective torque vs. speed" graph (reference).
 Note 3. For moment of inertia and effective torque details, see P.74.

Moment of inertia Acceleration/deceleration

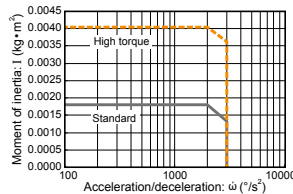

Effective torque vs. speed

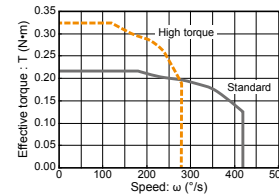

Allowable load

Allowable radial load (N)		Allowable thrust load (N)				Allowable moment (N·m)	
		(a)		(b)			
Standard model	High rigidity model	Standard model	High rigidity model	Standard model	High rigidity model	Standard model	High rigidity model
78	86	74	78	107	2.4	2.9	

Note. When purchasing the product, set the controller acceleration while carefully checking the "Moment of inertia vs. Acceleration/Deceleration" and "Effective torque vs. Speed" graphs.
 For details, please refer to the TRANSERVO Series User's Manual.

Controller

Controller	Operation method
TS-S2	I/O point trace / Remote command
TS-SH	I/O point trace / Remote command
TS-SD	Pulse train control

RF02-NN Limit rotation specification – Standard model

Stroke end
Origin position in CW rotation direction [Origin]³

Origin mark

Origin²
Origin position in CCW rotation direction [Stroke end]

310°

CCW direction

CW direction

Manual operation screw (both sides)

*1 Table movable range by return-to-origin operation.
Be careful not to interfere with the workpiece or equipment around the table.
 *2 Return-to-origin position
 *3 Values and characters in [] show those when the return-to-origin direction is changed.

Weight (kg) 0.49

Note 1. This drawing is output under the conditions below.
 Bearing Standard
 Torque Standard/High torque
 Note 2. The minimum bending radius of the motor cable is R30.
 Note 3. The motor cable exit direction is only the left side.

2-φ5.2 drill-through
φ9 deep spot facing,
Depth 5.5
P.C.D.32
6-M4x0.7 Depth 6
(60° equally divided.)

φ43h8^{+0.039}
φ42h8^{+0.039}

Approx. 170

(Motor cable exit direction: Exit from left side)

2-M6x1.0 Depth 12

RF02-NH Limit rotation specification – High rigidity model

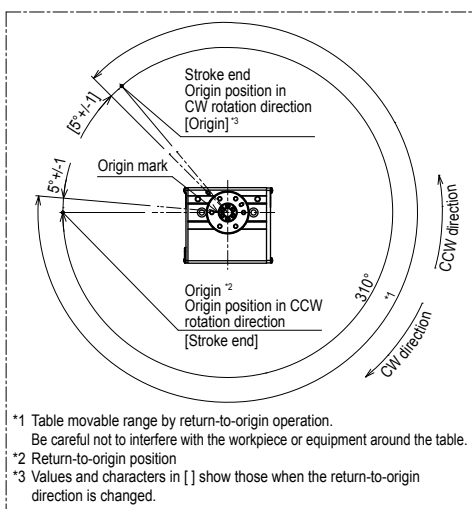

*1 Table movable range by return-to-origin operation. Be careful not to interfere with the workpiece or equipment around the table.
*2 Return-to-origin position
*3 Values and characters in [] show those when the return-to-origin direction is changed.

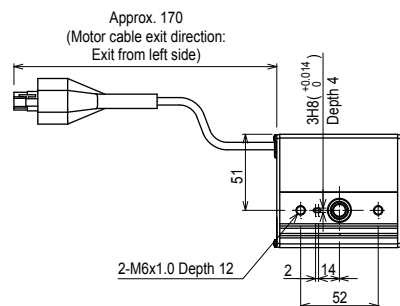
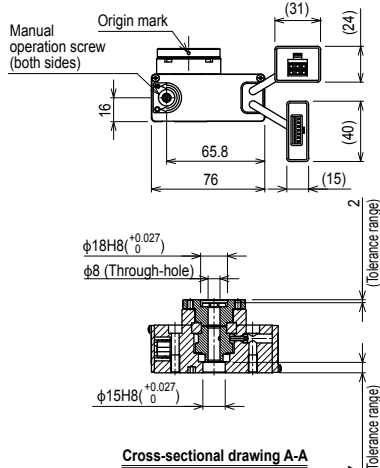
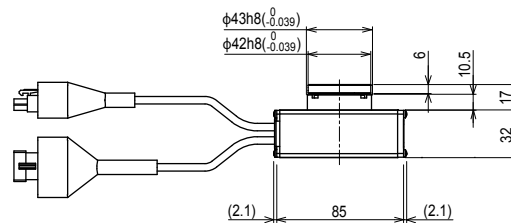
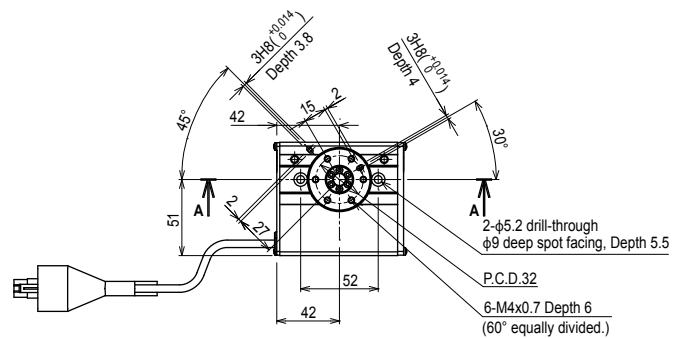

Weight (kg)	0.52
--------------------	------

Note 1. This drawing is output under the conditions below.
Bearing High rigidity
Torque Standard/High torque
Note 2. The minimum bending radius of the motor cable is R30.
Note 3. The motor cable exit direction is only the left side.