

RF04-SH Sensor specification – High rigidity model

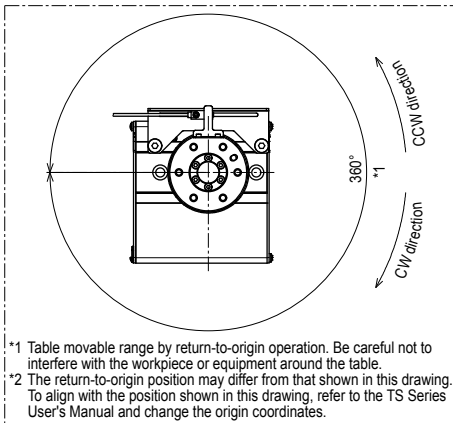

*1 Table movable range by return-to-origin operation. Be careful not to interfere with the workpiece or equipment around the table.
 *2 The return-to-origin position may differ from that shown in this drawing. To align with the position shown in this drawing, refer to the TS Series User's Manual and change the origin coordinates.

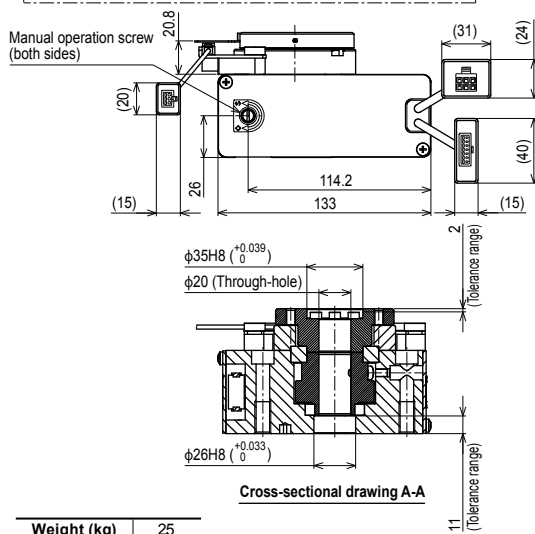

Cross-sectional drawing A-A

Weight (kg)	25
-------------	----

Note 1. This drawing is output under the conditions below.
 Bearing..... High rigidity
 Torque..... Standard/High torque
 Note 2. The minimum bending radii of the motor cable and sensor cable are R30.

